

# CONTENTS

## SAFETY, MAINTENANCE AND MOUNTING INSTRUCTIONS

### Volans and Crux Ex-eb Cable gland series

Types VOLE..., VOLEC..., VOLEF..., VOLEM...,



Types CRX..., CRXC..., CRXF..., CRXM...,



Rev. 0

## 3 IP PROTECTION for NON-THREADED HOLE

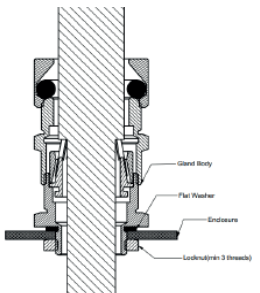

Recommended Hole Diameters For Non Threaded enclosure applications in relation with the used thread types are shown below.

METRIC THREADS		G THREADS(GAS ISO 228/1)		PG THREADS	
THREADS	HOLE DIAMETER (min-max mm)	THREADS	HOLE DIAMETER (min-max mm)	THREADS	HOLE DIAMETER (min-max mm)
M12 x 1.5	Ø12.0-12.5	G 3/8"	Ø16.6 - 16.8	PG 7	Ø12.5 - 12.7
M16 x 1.5	Ø16.0-16.5	G 1/2"	Ø21.0 - 21.2	PG 9	Ø15.2 - 15.4
M20 x 1.5	Ø20.0-20.5	G 3/4"	Ø26.4 - 26.6	PG 11	Ø18.6 - 18.8
M25 x 1.5	Ø25.0-25.5	G 1"	Ø33.3 - 33.6	PG 13.5	Ø20.4 - 20.6
M32 x 1.5	Ø32.0-32.5	G 1 1/4"	Ø41.9 - 42.2	PG 21	Ø28.3 - 28.5
M40 x 1.5	Ø40.0-40.5	G 1 1/2"	Ø47.8 - 48.1	PG 29	Ø37.0 - 37.3
M50 x 1.5	Ø50.0-50.5	G 2"	Ø59.6 - 59.9	PG 36	Ø47.0 - 47.3
M63 x 1.5	Ø63.0-63.5	G 2 1/2"	Ø75.2 - 75.5	PG 42	Ø54.0 - 54.3
M75 x 1.5	Ø75.0-75.5	G 3"	Ø87.9 - 88.2	PG48	Ø59.3 - 59.6
M80 x 1.5	Ø80.0-80.5	G 3 1/2"	Ø100.4 - 100.7		
M90 x 1.5	Ø90.0-90.5	G 4"	Ø113.1 - 113.4		
M100 x 1.5	Ø100.0-100.5	G 5"	Ø138.5 - 138.8		
M110 x 1.5	Ø110.0-110.5				
M115 x 1.5	Ø115.0-115.5				

## 4 IP PROTECTION for THREADED HOLE

### IP protection for cable glands with tapered thread

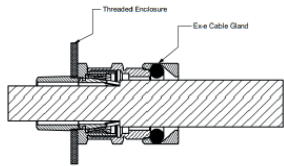

Remarks

> Ingress Protection: In order to guarantee the specified IP66/68 rating, sealant agent shall be applied on at least two full threads before fitting the gland to the box. In any case you must pay attention to guarantee the metallic continuity.

### IP protection mode for cable glands with cylindrical thread

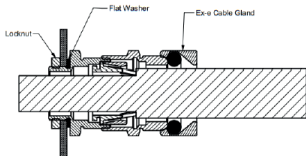

Remarks

> Ingress Protection: In order to guarantee the specified IP66/68 rating, it is recommended to use flat washer between the gland body and enclosure

> Assembling on Ex eb or Ex tb enclosures: You have to respect a minimum wall thickness of 1.5.

## 1 MARKINGS, APPLICABLE STANDARDS and SAFETY INSTRUCTIONS

### MARKINGS

Product marking for CRX..., CRXC..., CRXF..., CRXM... series		
Group II, III	CE0722	Ex eb IIC Gb; Ex tb IIIC Db IP66 Ta -60°C to +130°C CESI 21 ATEX 031 X IECEx CES 22.0009X

Product marking for VOLE..., VOLEC..., VOLEF..., VOLEM... series		
Group II, III	CE0722	Ex eb IIC Gb; Ex tb IIIC Db IP66/68 Ta -60°C to +130°C CESI 21 ATEX 031 X IECEx CES 22.0009X

### APPLICABLE STANDARDS

DIRECTIVE 2014/34/EU	EN/IEC 60079-7
EN/IEC 60079-0	EN/IEC 60079-31
	EN/IEC 60529

### SAFETY INSTRUCTIONS

- \* Changes to products are not allowed.
- \* Only BIMED spare parts must be used.
- \* Everyday and extraordinary maintenance operations must be carried out only by qualified personnel after approval from expert technicians.
- \* Cable glands are only suitable for fixed installations.
- Cables shall be effectively clamped to prevent pulling or twisting.
- \* The cable glands can be used with Ex i intrinsically safe circuits.
- \* The cable gland installation shall be done according to safety manufacturer instructions to maintain degree of protection.
- \* The end user shall ensure that the surface finish of the enclosure is smooth enough to obtain the required IP rating.
- \* It is recommended for enclosure entries to be perpendicular, circular and free of burrs.
- \* For non threaded enclosure applications, the end user shall respect the recommended hole diameters mentioned in the mounting instruction.

## 2 PREPERATION of CABLES

Please refer to the figure below, for details about the preparation of steel wire armour, braided and metal tape shielded cables for fitting into the cable gland.

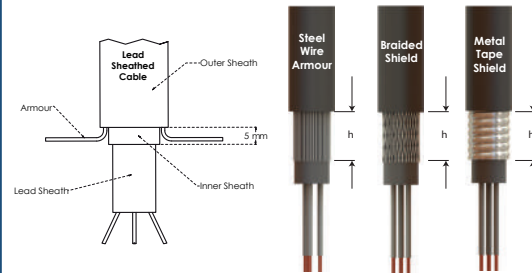

CABLE GLAND SIZE	M12, M16S, M16, M20S, M20, M25S, M25, M32S, M32, M40S	M40, M50S, M50, M63S, M63, M75S, M75, M80S, M90S	M80, M90, M100S, M100
CABLE STRIP LENGTH "h"	20 mm	25 mm	32 mm

## 5 TORQUE TABLE

### Torque table for cable gland models

VOLE..., VOLEC..., VOLEF..., VOLEM...,

CRX..., CRXC..., CRXF..., CRXM...,

Clamping Range	Torque of cable glands [ Nm ]	
	SW2	SW3
Min.-Max.		
5,5-12,0	15	15
9,0-16,0	20	20
12,0-20,0	20	20
16,0-26,0	20	20
20,0-33,0	25	25
29,0-41,0	50	50
36,0-52,0	55	55
50,0-65,0	100	100
61,0-78,0	125	125
75,0-89,0	200	200
75,0-89,0	200	200
88,0-104,0	270	270

Clamping Range	Torque of cable glands [ Nm ]	
	Min.-Max.	SW2
3,0-8,0		5
5,5-12,0		10
12,0-20,0		20
16,0-26,0		25
20,0-33,0		30
29,0-41,0		35
36,0-52,0		40
50,0-65,0		50
61,0-78,0		50
75,0-89,0		65
88,0-104,0		70

## 6 EU DECLARATION of CONFORMITY



### EU DECLARATION OF CONFORMITY

**bimed**

Bimed Teknik Aletler San. ve Tic. A.Ş.  
S.S. Bakır Piriň Sanayi Şifesi Leylak Cad. No:16 34524 Beylikdüzü/ İstanbul TURKİYE  
Tel: +90 212 8757376 Fax: +90 212 8750823

declares that the products designed to be placed on the market for use in the explosive atmospheres described below are in conformity with the listed EU Directive and harmonized standards.

Cable Gland Types: VOLE..., VOLEC..., VOLEF..., VOLEM...,

Protection Type: Ⓜ II 2GD; Ex eb IIC Gb; Ex tb IIIC Db IP66

Cable Gland Types: CRX..., CRXC..., CRXF..., CRXM...,

Protection Type: Ⓜ II 2GD; Ex eb IIC Gb; Ex tb IIIC Db IP66/68

Certificate Number: CESI 21 ATEX 031 X  
EU Directive: ATEX 2014/34/EU  
The harmonized standards applied: EN IEC 60079-7:2015/A1:2018  
EN IEC 60079-31:2014

**FACSIMILE**

Notified body CESI 0722

Istanbul, 11.10.2021

General Manager  
Yüksel Gökbuğulu  
TEKNİK ALETLER SANAYİ VE TİCARET

7

### Detailed Sub-Parts for Cable gland type CRX

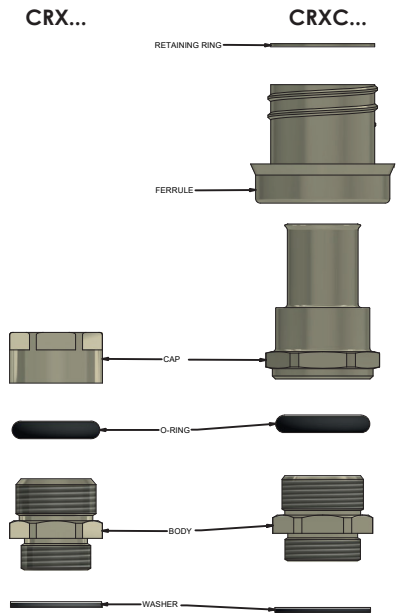

8

### PRODUCT SUB PARTS

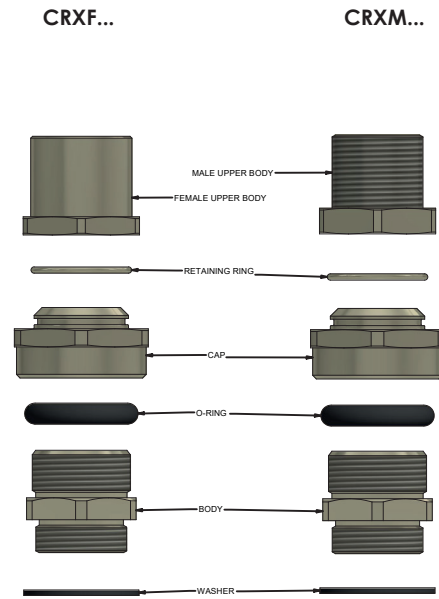

9

### PRODUCT SUB PARTS

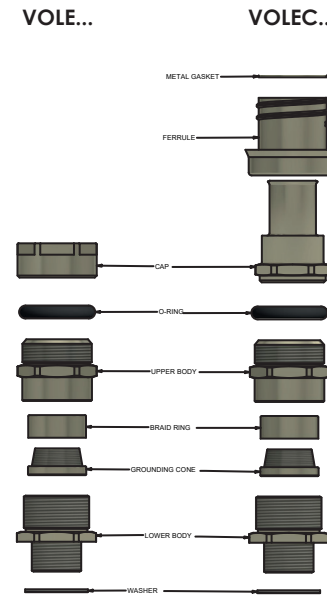

10

### PRODUCT SUB PARTS

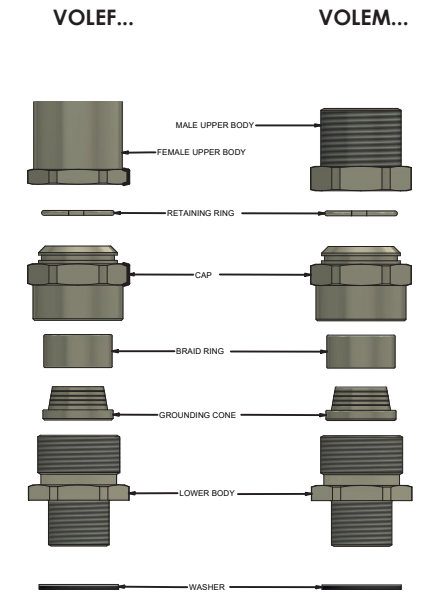

Rev. 0

11

### MOUNTING INSTRUCTIONS

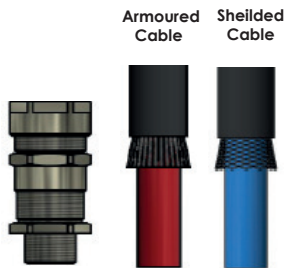

**Step 1** - Choose the optimal cable according to clamping ranges submitted in the certificate and prepare the cable for installation. All sub-parts required for installation are shown respectively above.

12

### MOUNTING INSTRUCTIONS

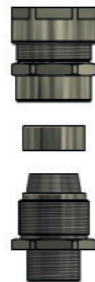

**Step 2** - Separate lower body and upper body from each other so that ensure grounding cone is visible in the lower body. Mount the lower body to the appropriate opening on enclosure and tighten with sufficient torque value. Use locknut to tighten if the enclosure is non-threaded.

13

### MOUNTING INSTRUCTIONS

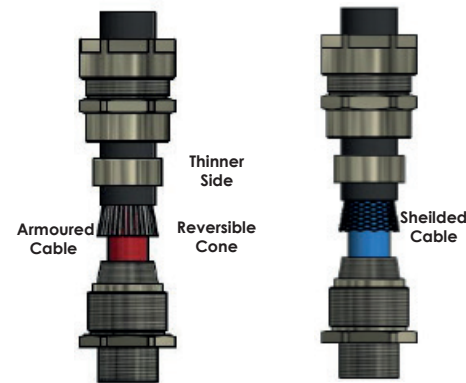

**Step 3** - Insert the cable to the inside of upper body. Pay attention to the direction of the Reversible cone. If steel wire armoured cable is mounted, cable armours must be clamped with thinner side of the reversible cone.

14

### MOUNTING INSTRUCTIONS



**Step 4** - Tighten the upper body with sufficient torque value. For torque values please refer the tables "Sizes and torque of cable glands". Visually check if armour is securely clamped. If not, repeat the clamping process.